



Power Electronic Systems
Laboratory

© 2012 IEEE

Proceedings of the International Conference of Integrated Power Electronics Systems (CIPS 2012), Nuremberg, Germany,
March 6-8, 2012

Integration of Leakage Inductance in Tape Wound Core Transformers for Dual Active Bridge Converters

B. Cougo,
J. W. Kolar

This material is published in order to provide access to research results of the Power Electronic Systems Laboratory / D-ITET / ETH Zurich. Internal or personal use of this material is permitted. However, permission to reprint/republish this material for advertising or promotional purposes or for creating new collective works for resale or redistribution must be obtained from the copyright holder. By choosing to view this document, you agree to all provisions of the copyright laws protecting it.



Eidgenössische Technische Hochschule Zürich
Swiss Federal Institute of Technology Zurich

Integration of Leakage Inductance in Tape Wound Core Transformers for Dual Active Bridge Converters

Bernardo Cougo and Johann W. Kolar, ETH Zurich, Power Electronic Systems Laboratory, Zurich, Switzerland.

Abstract

Dual Active Bridge (DAB) converters are nowadays used in applications such as automotive and general energy storage interfaces, where efficient and compact isolated bidirectional DC/DC converters are required. The heart of this converter is a transformer which, in some designs, may include the required inductance to shape the current and control the energy transfer. This paper shows that for these designs, tape wound cores, usually made of amorphous or nanocrystalline materials, are not the best core option due to leakage flux which is orthogonal to the lamination layers. This flux increases losses in these types of cores. Solutions are proposed to overcome this significant drawback. Analysis developed in this paper is validated by experimental results, which show that core losses due to orthogonal flux in a tape wound core transformer can be reduced more than 6 times if an adapted leakage layer is used instead of a regular one.

1 Introduction

In a world of growing energy consumption and increasing efficiency needs, DAB converters are one of the most promising topologies for isolated bidirectional DC/DC conversion as required for automotive [1], energy storage interface [2] and medium-voltage power conversion systems [3,4]. These converters are composed of two bridges connected through a transformer providing galvanic isolation. An inductance is necessary to shape the current in the transformer and also to control the power to be transferred in the system [4]. A typical DAB converter configuration is shown in **Fig. 1**.

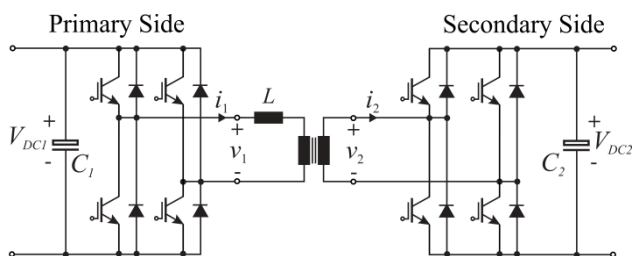

Fig. 1 Typical DAB converter.

The inductor and transformer used in DAB circuits are usually designed for low losses and volumes. One of the ways of obtaining that is by integrating the required inductance into the transformer. Low losses and volume can also be achieved by choosing high performance magnetic materials such as nanocrystalline tape wound cores, which present low specific losses at high frequencies and high saturation flux density (around 1.2T). However these types of cores have a major drawback when the required inductance is integrated as will be discussed in this paper. **Section 2** shows examples of required inductances integrated into transformers and explains the influence of the leakage inductance on the currents flowing in the transformer. In **Section 3**, tape wound cores are considered and a major drawback con-

cerning the use of the leakage inductance is identified. Solutions to overcome this drawback are proposed in **Section 4**. In **Section 5**, experimental results are presented to confirm the drawbacks related to the inductance integration and also to verify the proposed solutions

2 Leakage Inductance of a Transformer

In the design of magnetic components of a DAB converter, the inductor (L in **Fig. 1**) can be designed and externally connected to the transformer or it can be integrated into the transformer. For high frequency and high power applications, low inductance values are needed and thus the leakage inductance of the transformer can be used. This leakage inductance value is closely related to the transformer structure and its calculation may require time-consuming 3D Finite Element Method (FEM) simulations for some cases. Four transformer structures used for high power and high frequency applications are shown in **Fig. 2**. The structure in **Fig. 2a** has one winding on the top of the other, and they are enclosed by magnetic material. This is the structure of the transformer used in the MEGACUBE project [5], which is part of a 166kW/20kHz DAB converter. With this structure, the leakage inductance can be easily and precisely calculated given that the leakage energy is mainly concentrated in the region in between the windings. Low leakage inductances may be achieved with this structure and the core can be more easily cooled since most of its surface is in contact with air.

Fig. 2b shows the transformer structure used in [6]. In this structure both the primary and secondary are wound on both legs of the magnetic core in a concentric arrangement. The leakage inductance can be controlled by the distance between the concentric windings and it may be kept low since by interleaving the windings.

Fig. 2c shows a simple structure where each leg of the core has one different winding. This structure is more easily built but it has the drawback that most of the leakage energy is contained outside the core window. Thus, the leakage inductance cannot be easily predicted by analytical calculation and consequently 2D or 3D FEM simulation is necessary. In this configuration, high leakage inductance is expected as well as high electromagnetic interference with electronic devices close to the transformer.

For applications where high inductances are needed, a good option to increase the leakage inductance is to use a leakage layer in the transformer [7]. A central leg made of magnetic material is inserted inside the transformer window, between the two windings, as shown in **Fig. 2d**. This central leg can have a cross section smaller than that of the other legs if the leakage flux is lower than the magnetizing flux, which is typically the case in a DAB transformer. This option is usually more compact than building an external inductor since only a single core and 2 windings are used.

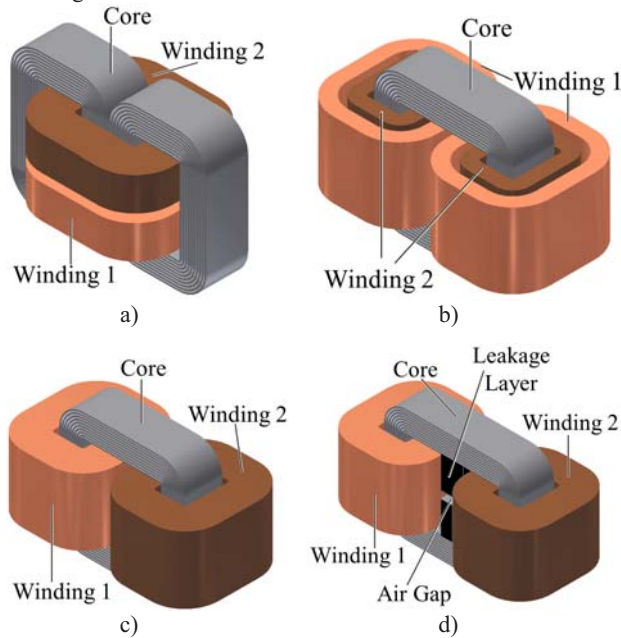

Fig. 2 Different structures of transformers for DAB converters; a) structure with one winding on the top of the other, allowing low leakage inductance which can be precisely calculated; b) structure with two concentric and interleaved windings, used to achieve low leakage inductance; c) structure with separate windings, which allows easier cooling but shows high leakage inductance which is difficult to estimate by analytical calculations; d) structure with separate windings and leakage layer used to increase the leakage inductance.

The design of a transformer significantly depends on the calculation of core losses. Precise core loss calculation is only possible by knowing the waveform of the flux inside the core and the core loss model parameters associated to the core material.

Precise calculation of core losses for high frequency flux with non-sinusoidal waveform can be achieved with iGSE (improved Generalized Steinmetz Equations [8]), which is given by the following formulas, applied to one switching period T :

$$P_v = \frac{1}{T} \int_0^T k_i \left| \frac{dB}{dt} \right|^\alpha (B_{pp})^{\beta-\alpha} dt, \quad (1)$$

$$k_i = \frac{k}{(2\pi)^{\alpha-1} \int_0^{2\pi} |\cos \theta|^\alpha 2^{\beta-\alpha} d\theta}, \quad (2)$$

where B_{pp} is the peak-to-peak value of the flux density in the core and k , α and β are the same parameters as used in the well-known Steinmetz Equations, which are given by the core manufactures or extracted from the datasheet of the core.

The flux in each part of the core can be different depending on the chosen structure. If the structure in **Fig. 2d** is taken as an example, an equivalent magnetic circuit can be derived, as shown in **Fig. 3a**. In a DAB converter, different voltages are applied to different windings of the transformer and consequently different fluxes are present in different core legs (fluxes ϕ_1 and ϕ_2 in **Fig. 3a**). These fluxes can be calculated as

$$\phi_x(t) = \frac{\int v_x(t) dt}{N_x} \quad (3)$$

where N_x is the number of turns of the corresponding winding and v_x is the voltage applied to the corresponding winding.

The difference between these fluxes (ϕ_a) will flow through the central leg and thus a magnetomotive force over the air gap reluctance R_a can be calculated as

$$\begin{aligned} MMF_a(t) &= R_a \cdot (\phi_1(t) - \phi_2(t)) = \\ &= R_a \cdot \int \left(\frac{v_1(t)}{N_1} - \frac{v_2(t)}{N_2} \right) dt \end{aligned} \quad (4)$$

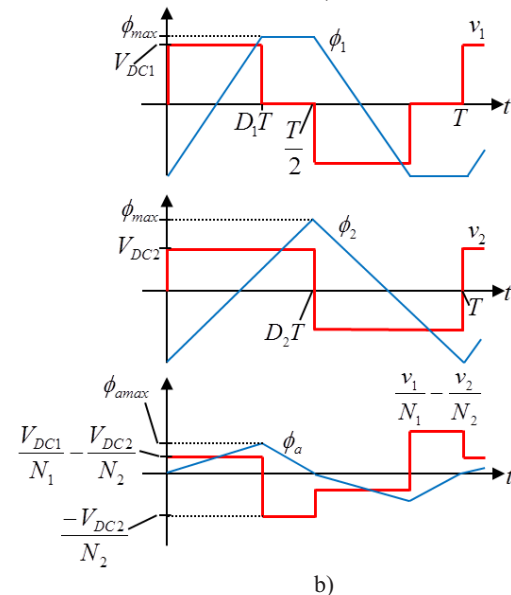
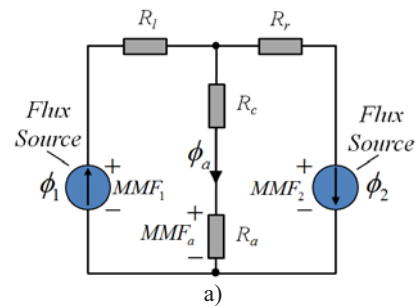

Fig. 3 a) Simplified magnetic circuit of a transformer for DAB converter. b) Typical transformer voltage and flux waveforms for DAB converter working in ZCS mode at duty cycles $D_1=0.35$, $D_2=0.50$.

Since the core reluctances (R_l , R_r and R_c) are much smaller than the air gap reluctance, the magnetomotive forces at windings 1 and 2 (respectively MMF_1 and MMF_2 in **Fig. 3**) will be the practically the same as the magnetomotive force over the air gap. Consequently, the current in each winding is:

$$i_x(t) = \frac{MMF_a(t)}{N_x} = \frac{R_a}{N_x} \cdot \int \left(\frac{v_1(t)}{N_1} - \frac{v_2(t)}{N_2} \right) dt \quad (5)$$

Fig. 3b shows an example of the fluxes in each part of the core if the DAB converter is working in Zero Current Switching mode [4] with duty cycle of $D_1=0.35$ and $D_2=0.5$ in the primary and secondary sides respectively. This shows that each part of the magnetic circuit has a different flux waveform and that these different waveforms have to be taken into account in the calculation of the core losses.

2.1 Calculation of the leakage inductance

In the analysis shown above, the air gap reluctance is used to change the amplitude of the current flowing in the transformer [cf. (4) and (5)]. For the other structures of **Fig. 2** which do not have a central leg with air gap, the current amplitude is determined by the leakage inductance. For the simple magnetic circuit of **Fig. 3a**, R_a can be calculated as

$$R_a = \frac{N_x^2}{L_x} \quad (6)$$

where L_x is the leakage inductance seen from the primary ($x=1$) or secondary side ($x=2$) and N_x is the number of turns corresponding to the winding which the inductance is being calculated for.

Leakage inductance of transformers can be either analytically calculated or simulated, depending on the transformer geometry. For the transformer of **Fig. 2a**, for example, the leakage inductance can be analytically calculated according to [9] (cf. **Fig. 4**)

$$L_x = l_{av} \cdot \mu_0 \cdot \frac{N_x^2}{h} \cdot \left[b_3 + \left(\frac{b_1 + b_2}{3} \right) \right] \quad (7)$$

where b_1 and b_2 are the width of the primary and secondary windings, b_3 is the distance between the windings inside the core window, h is the core window height, l_{av} is the mean length turn of the winding and μ_0 is the air permeability.

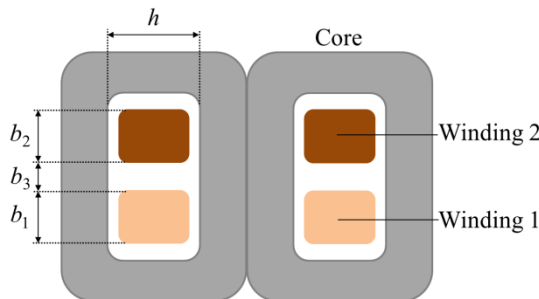

Fig. 4 Geometrical parameters of a transformer used to analytically calculate its leakage inductance.

3 Tape Wound Cores

The choice of the core material is strongly influenced by the application and final objective. If the objective is to reduce the cost

of the transformer, low cost materials such as ferrites and some iron powders are usually used. For high power density designs, tape wound cores made of nanocrystalline or amorphous materials are promising options. Nanocrystalline materials may achieve low specific losses for higher flux densities. Given their small tape (or layer) thickness (around $20\mu\text{m}$), eddy currents in the magnetic material are reduced while maintaining high saturation flux density (around 1.2T). However, these types of cores present a major drawback when used in transformers where high leakage inductance is necessary: flux orthogonal to the layer. If a flux is perpendicularly to the layers, eddy currents are created in the plane of the layers, which might generate much higher losses in the material since these currents will flow in a much larger area where the skin effect is significant. This can be seen schematically in **Fig. 5**.

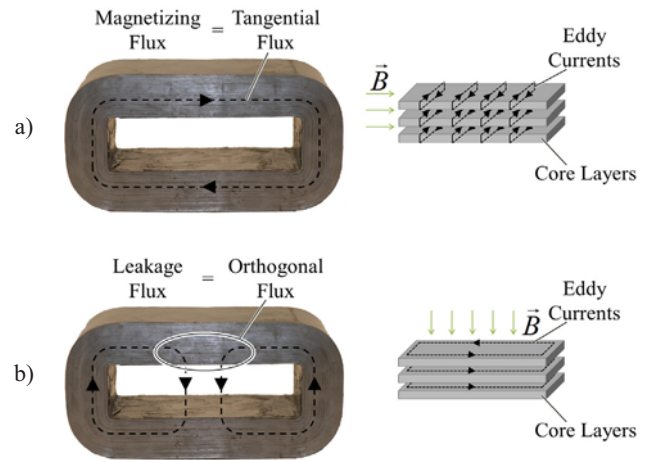

Fig. 5 Tape wound core having a) tangential flux and b) orthogonal flux to the layer plane. Orthogonal flux generates much higher eddy currents, and consequently, much higher losses than tangential flux.

Taking **Fig. 3a** as reference, it can be seen that the magnetizing flux in the transformer is in the direction of the layers while the leakage flux is perpendicular in the region close to the top and bottom legs. If a leakage layer is used (example in **Fig. 2d**), the flux in the central leg is perpendicular to layers in the tape wound core in the region close to the contact between the core and the leakage layer. This may generate significant extra losses, as it will be seen in the experimental results.

These losses are higher in the inner and outer-most layers of the core given that all the leakage flux in the core is orthogonal to these layers. This can be seen on **Fig. 6**, where the structure of **Fig. 2c** is simulated using a 2D FEM software, and applying equal currents in the primary and secondary windings so only the leakage flux is present in the core. By the flux lines, one can see that most of the orthogonal components of the leakage flux are present in the inner- and outer-most layers.

Higher losses due to orthogonal flux do not exist in ferrite since this is an isotropic material and core losses are independent of the flux direction.

Given the 3D nature of the core and the complexity of the phenomena, it is rather complicated to deduce an analytical approximation for the increase of core losses due to eddy currents generated by orthogonal flux.

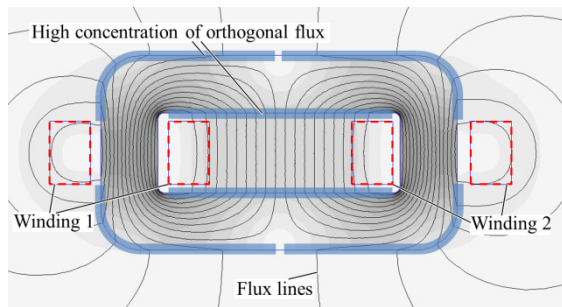

Fig. 6 Leakage flux in transformer with high leakage inductance. All the leakage flux is orthogonal to the plane of the inner- and outer-most layers of the tape wound core which generates higher losses at these layers. Colors in grayscale represent the absolute value of the flux density.

4 Adapted Leakage Layers

Transformers requiring high leakage inductances may make use of a leakage layer as shown in **Fig. 2d**. The flux in the leakage layer is orthogonal to the plane of the layers of the tape wound core in the region close to the contact of the core and the leakage layer. This orthogonal flux generates extra core losses which are not taken into account in a transformer design and which are not measured in a regular transformer test, where only the losses due to the magnetizing flux are measured. This may be one of the reasons why authors in [7] reported much higher losses than expected for two transformers made with nanocrystalline material having different leakage layers.

Solutions are proposed here so that designers can use tape wound cores and avoid large orthogonal flux. The most straight forward and bulky option is to use an external inductor and design the transformer with very low leakage inductance. A second solution would be to transfer the leakage inductance of the transformer to an extra magnetic material which would be inserted in one or both windings, as the ones shown **Fig. 7a** and **Fig. 7b**.

The third solution would be to change the layer direction in relation to the leakage flux. This was already done for amorphous material in motor applications [10]. One of the ways of doing this is to build a core using I-cores made of stacked layers. These I-cores are commercially available for amorphous material. Finally, the fourth solution is the most compact and promising one. The idea is to use a leakage layer which does not generate orthogonal flux. For this, two options are shown in **Fig. 7c** and **Fig. 7d**. In **Fig. 7c**, the leakage layer is placed on the front and back surfaces of the tape wound core. Thus the flux in the region of contact between the leakage layer and the core is perpendicular to the front and back surfaces of the tape wound core and not to the plane of the layers of the core. In **Fig. 7d**, the leakage layer is placed between two core halves, forcing the leakage flux to change its direction only inside the leakage layer. In this configuration, the magnetizing flux is also present in part of the leakage layer. In the configurations of **Fig. 7c** and **Fig. 7d**, if the leakage layer uses a laminated material, a correct orientation of the lamination must be observed in order to avoid orthogonal flux in the leakage layer.

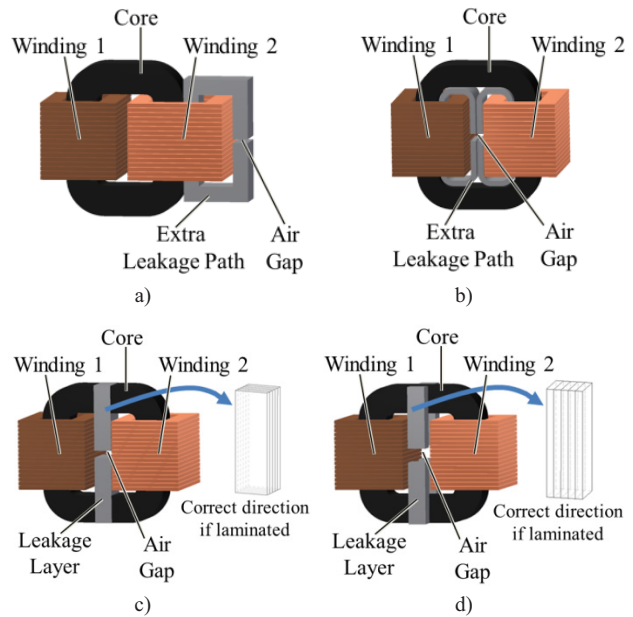

Fig. 7 Different configurations of transformers having an adapted leakage path. Extra core a) outside and b) inside the main core window; c) leakage layer outside the main core; d) leakage layer between two core halves. These leakage layers avoid a flux orthogonal to the plane of the layers of the tape wound core in the region close to the contact between the leakage layer and the tape wound core.

5 Experimental Results

Experiments are proposed in order to verify the analysis presented in this paper.

To show that there is a high concentration of orthogonal flux in the inner- and outer-most layers, as shown in **Fig. 6b**, the transformer of **Fig. 8a** was built with no leakage layer. It uses a commercial VITROPERM 500F nanocrystalline cut core T60102-L2198-W171 from VacuumSchmelze. Two identical windings were wound in the core, each with 22 turns, made of two parallel litz wires in order to present much lower copper losses than losses generated in the core. The same square wave voltage (218V at 20kHz) was applied to both windings in a direction such that there is only leakage flux in the core and practically no magnetizing flux. A thermal picture of the transformer in these conditions was taken and is shown in **Fig. 8b**. Colors at the inner and outer-most layers show that the temperatures in these layers are higher than in the middle layers, indicating that there is a high concentration of orthogonal flux (and consequently of losses) in these layers, as shown in **Fig. 6**.

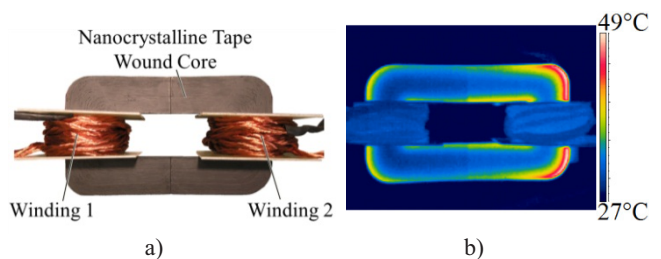

Fig. 8 a) Nanocrystalline transformer with 2 windings of 22 turns; b) Thermal image of the transformer indicating that the inner and outer-most layers have higher temperatures due to the concentration of leakage flux which are orthogonal to these layers, causing higher losses.

The transformer of **Fig. 8a** was used to measure the losses due to the leakage flux. For that, a voltage was applied to the primary winding and the secondary was short-circuited, creating a relatively large leakage flux. Four configurations were tested:

- 1 - secondary open-circuited and no leakage layer (**Fig. 8a**); only magnetizing flux is present in the core;
- 2 - secondary short-circuited and regular leakage layer made with ferrite material inside the core window (**Fig. 9a**);
- 3 - secondary short-circuited and adapted leakage layer made with ferrite material outside the core window (**Fig. 9b**);
- 4 - secondary short-circuited and no leakage layer (**Fig. 8a**).

Measured losses were obtained using a Yokogawa WT3000 high precision power analyzer and they are shown in **Fig. 9c** for a square voltage at 20kHz applied to the primary winding (Winding 1). In both configurations with leakage layer (configurations 2 and 3), the air gap was adjusted so both transformers could have the same leakage inductance.

These results clearly show that orthogonal flux (present in configurations 2 and 4) generates very high losses in transformers where leakage flux is important. In configuration 1, only magnetizing flux is present in the core and consequently no extra losses are observed. The solution proposed with the adapted leakage layer and shown in **Fig. 7c** (configuration 3) is effective to have high leakage inductance generating low extra losses due to orthogonal flux.

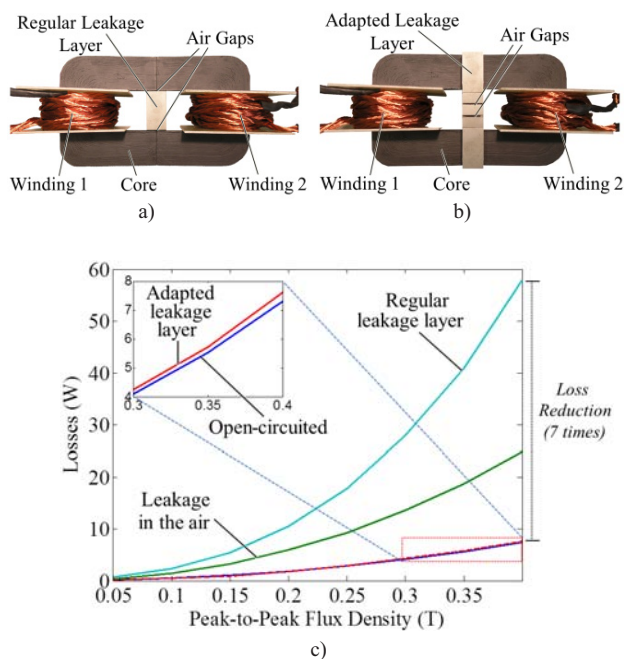

Fig. 9 Transformers with a) regular and b) adapted leakage layer; c) measured core losses for transformers with and without leakage layers. Measurements indicate that extra losses due to orthogonal flux are high (more than 7 times higher if the losses in a transformer with regular leakage layer are compared to those in a transformer with adapted leakage layer).

A DAB converter was built to verify the increase of core losses in tape wound core transformers. Two full bridges with maximum DC bus of 400V and switching frequency of 50kHz were used. Each applied to the corresponding transformer winding, a squared waveform having 50% duty cycle. Phase shift between

the switching signals of both full bridges are varied from 0 to 180° to change the transferred power. Transferred power increases for phase shift from 0 to 90° and it decreases from 90° to 180°. In normal operation, DAB circuits do not operate with phase shift from 90° to 180° since high reactive power circulates in the converter, but here it is done to investigate the increase of core losses due to orthogonal flux. As shown in **Section 2**, the voltage difference between both full bridges imposes a leakage flux in the transformer. So, in the DAB converter, the greater the phase shift between voltages on both sides, the higher the leakage flux.

Three transformers were used in this test: one with nanocrystalline core with no leakage layer (**Fig. 8a**), with regular leakage layer (**Fig. 9a**) and with adapted leakage layer (**Fig. 9b**); one with tape wound core made of amorphous material (**Fig. 10a**) and the other made with ferrite N87 (core U93/76/16 from EP-COS). **Fig. 10a** shows the experimental setup with the tape wound amorphous core and **Fig. 10b** presents the measured voltages and current for a phase shift close to 90° when using the tape wound core transformer. **Fig. 11** shows the core losses measured in the three transformers for different phase shifts between the voltages applied to the transformer windings, normalized by the corresponding losses measured with the secondary winding opened, which is the approach most transformer designers use to predict core losses in transformers. Litz wires were used for the windings and so copper losses are low when compared to core losses. Nevertheless, 2D FEM simulations were performed to predict high frequency copper losses so they could be subtracted from the measured loss values.

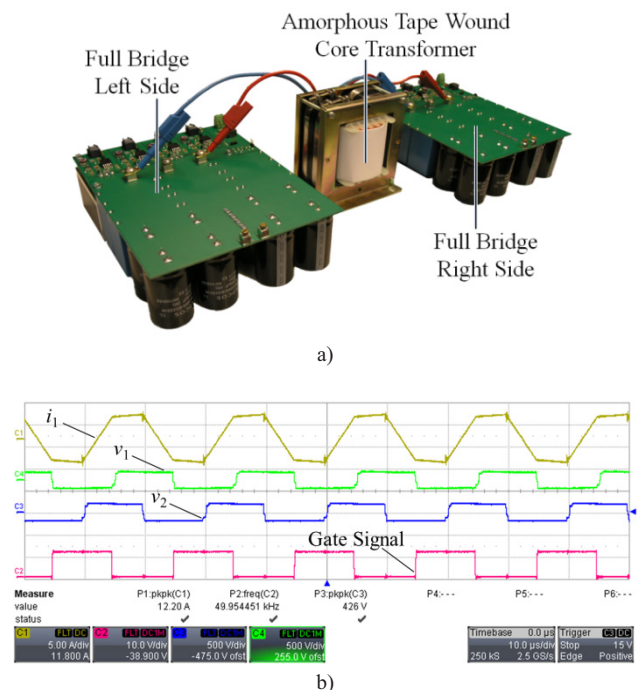

Fig. 10 a) DAB converter with amorphous tape wound core transformer; b) measured current and voltages for phase shift of 90° between voltages applied to the primary and secondary windings.

As shown in **Fig. 11**, losses in the ferrite transformer slightly increase when the phase shift between the voltages is increased. Since there is no orthogonal flux in ferrite material, losses may

slightly vary with the phase shift since field distribution changes inside the core. All tape wound core transformers had their losses significantly increased when phase shift is increased. Note that, when compared to the regular leakage layer configuration, the adapted leakage layer reduced more than 6 times the core losses at 90° (maximum power transfer angle), confirming that this solution is effective to reduce extra core losses due to orthogonal flux in tape wound core.

From the minimum to the maximum power transfer states (0 to 90° phase shift), tape wound core transformers with no leakage layer had their losses increased approximately 3.7 and 3.0 times for, respectively, nanocrystalline and amorphous materials. This shows that core losses in DAB transformers with no leakage layer and employing tape wound cores, cannot be simply predicted by regular analytical formulas [such as (6) and (7)] or by measured losses with the secondary open-circuited.

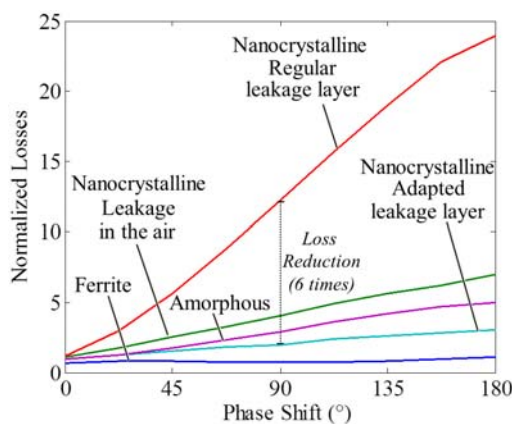

Fig. 11 Measured core losses for ferrite and amorphous and nanocrystalline tape wound core transformers, for different phase shifts between voltages applied to the primary and secondary windings. Losses are normalized to the corresponding measured losses with the secondary open-circuited.

6 Conclusions

DAB converters make use of transformers to provide galvanic isolation and inductors as energy transfer components. In compact designs, these two magnetic components should be integrated using the same magnetic core. High performance magnetic materials, which are usually built in tape wound structures, allow a compact design of magnetic components. This paper shows that integration of the inductance into transformers made with tape wound cores either by using the leakage inductance of the transformer or by adding a regular leakage layer (**Fig. 2d**), is not recommended since high core losses will be generated given that the leakage flux, in some regions of the core, has a direction orthogonal to the layers of the magnetic core.

Simulation and experimental results shown in this paper verified the increase of core losses due to orthogonal flux. It was shown that a higher concentration of orthogonal flux is observed in the inner and outer-most layers, generating higher losses in these layers.

Solutions to overcome the problem of having orthogonal leakage flux were proposed and experimentally tested. An experimental DAB converter was used to measure losses in a trans-

former having an adapted leakage layer. This configuration reduced 6 times the core losses at the maximum power transfer operation, when compared to the transformer with a non-adapted leakage layer. These experimental results confirm that orthogonal flux significantly increases core losses in transformers employing tape wound cores and used in DAB converters and that leakage layers used to increase the leakage inductance can only be used if adapted to generate low orthogonal flux.

Furthermore, experimental results with the DAB converter shows that amorphous and nanocrystalline tape wound core transformers even with no leakage layer presented more than 3 times higher core losses than expected, when the power transferred in the system is maximum. A transformer made of ferrite was also tested and negligible core loss increase was observed.

7 References

- [1] F. Krismer, J. W. Kolar, "Accurate small-signal model for the digital control of an automotive bidirectional dual active bridge," *IEEE Tran. Power Electr.*, vol. 24, n. 12, pp. 2756–2768, Sept. 2009.
- [2] H. Zhou, A. M. Khambadkone, "Hybrid modulation for dual active-bridge bidirectional converter with extended power range for ultracapacitor application," *IEEE Trans. Ind. Applic.*, vol. 45, n. 4, pp. 1434–1442, July/Aug. 2009.
- [3] S. Inoue, H. Akagi, "A bidirectional isolated dc-dc converter as a core circuit of the next-generation medium-voltage power conversion system," *IEEE Trans. Power Electr.*, vol. 22, pp. 535–542, Mar. 2007.
- [4] G. Ortiz, J. Biela, D. Bortis, J. W. Kolar, "1 megawatt, 20 kHz, isolated, bidirectional 12kV to 1.2kV DC-DC converter for renewable energy applications," *IEEE ECCE Asia*, Sapporo, Japan, June 2010.
- [5] J. W. Kolar, "Intelligent solid state transformers (SSTs) - A key building block of future smart grid systems," presentation only, no paper. CPSSC, Shanghai, China, Nov. 2011.
- [6] H. Hoffmann, B. Piepenbreier, "Medium frequency transformer for rail application using new materials," *EDPC*, pp. 192-197, Nuremberg, Germany, Sept. 2011.
- [7] M. Pavlovsky, S. W. H. de Haan, J. A. Ferreira, "Winding losses in high-current, high-frequency transformer foil windings with leakage layer," *IEEE PESC*, Jeju, South Korea, June 2006.
- [8] J. Li, T. Abdallah, C. R. Sullivan, "Improved calculation of core loss with nonsinusoidal waveforms," *IEEE IAS Annual Meeting*, vol. 4, pp. 2203–2210, Chicago, USA, Sept. 2001.
- [9] Wm. T. McLyman, *Transformer and inductor design handbook*, Dekker Edition, 2004.
- [10] A. Chiba, H. Hayashi, K. Nakamura, S. Ito, K. Tungpimolrut, T. Fukato, M. A. Rahman, M. Yoshida, "Test results of a SRM made from a layered block of heat-treated amorphous alloys," *IEEE Trans. Ind. Applic.*, vol.44, n.3, pp. 699–706, May-June 2008.